

Piper Cheyenne IIIA D-IDBU

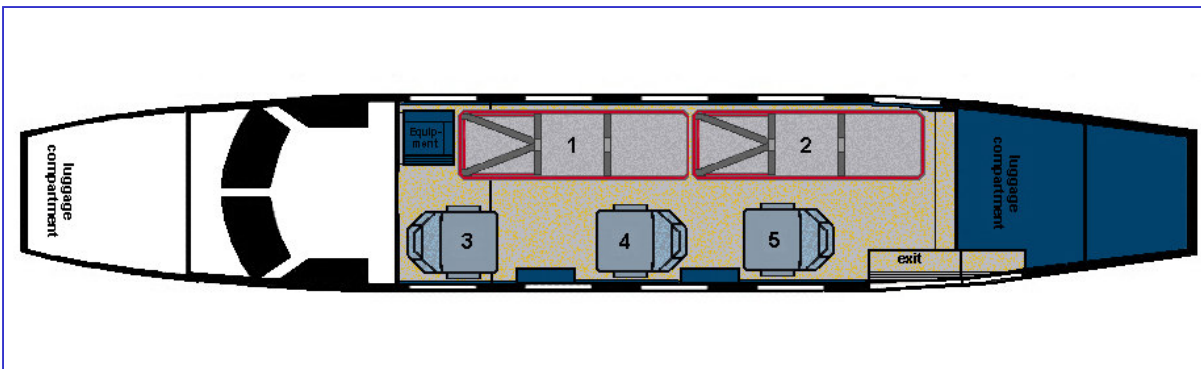

Dedicated Air Ambulance



Double-Stretcher-Configuration



**State-of-the-art
Stretcher System**



**Cargo-Door
with Loading-Ramp**

Piper Cheyenne IIIA D-IDBU

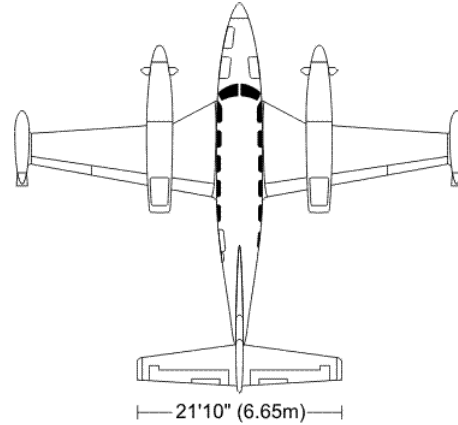
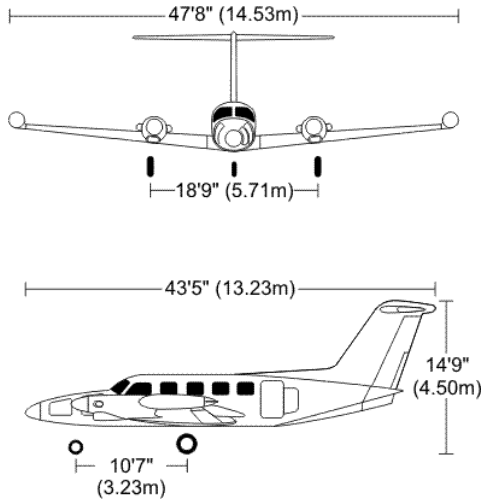

Aircraft Specification:

Producer:	Piper, Lockhaven PA, USA
Engines:	Pratt and Whitney PT6A-61, 720 HP per engine
Speed:	290 kts (~ 500 km/h)
Range:	1500 nm (~ 2750 km)
TO-Runway-Length:	min. 1000 m
max. TO-Weight:	5.100 kg
Crew:	2 Pilots Physician + Nurse/Paramedic
max. Passengers:	2 stretchered Patients + 1 seated Patient or 1 Companion

Medical Equipment:

General:	Lifeport Double-Stretcher-System with Loading-Ramp, Emergency-Back-Pack, Drugs/Medicaments, Oxygen, Suction-Unit, Vacuum-Mattress, Spines etc.
Ventilator:	Mallinckrodt Achieva PS
Monitoring:	ECG, EBP, IBP, SaO2, CO2, Temp., Blood-Gas-Analyser
Circulation:	Defibrillator with Pacer, Syringe- and Infusion-Pumps
Optional:	Neonatal Intensive-Care-Unit